

EFIS Single SIM Installation

Left Ignition

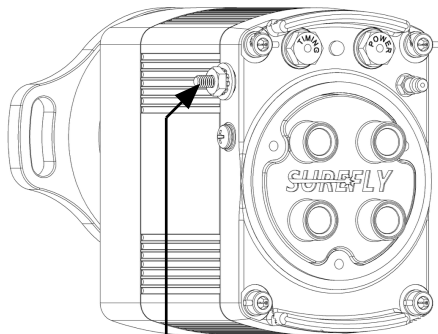

Left Plead Wire *

Right Ignition

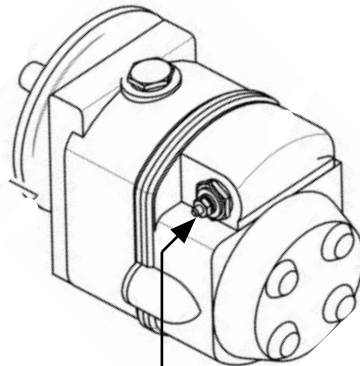

Right Plead Wire *

Electronics International

Engine Module

Input parameters:

0-5V Square wave

4 Cylinder - 1 Pulse per rev

6 Cylinder - 1.5 Pulse per rev

L Plead input
R Plead input

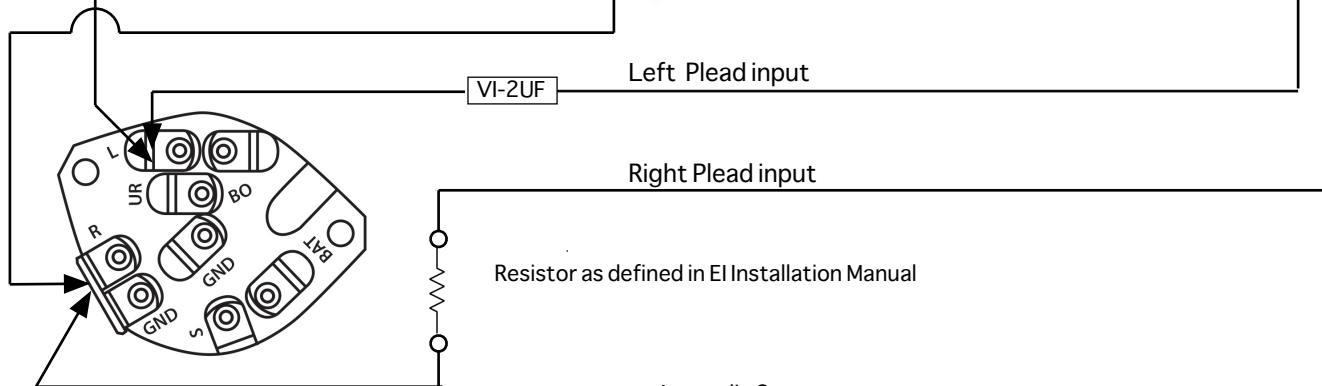

Appendix G